

ELEGANT SERIES

FOR VERSATILITY AND JOY OF WORK

Modern machine with a high number of ergonomic elements and integrated sprinkling system for an asphalt compaction. Whatever application is planned, vibratory plates of Elegant series are always ready.

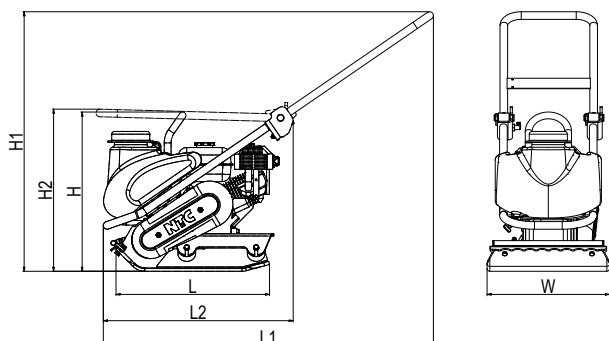



TYPE	Machine dimensions (mm)						
	VD 15	H	H1	H2	L	L1	L2
	745	930	750	565	1200	695	400

TECHNICAL PARAMETERS

OPERATIONAL PARAMETERS

Operational weight	[kg]	85
Plate dimensions (W x L)	[mm]	450 x 565
Centrifugal force	[kN]	15
Frequency	[Hz]	100
Maximal speed	[m/min]	25

ENGINE

Maker and type	Honda	GX 160
Fuel	[-]	Petrol
Net power (3600 r./min)	[kW]	3,6
Emission class	[-]	EU Stage V

OPERATIONAL LIQUIDS

Fuel tank capacity (petrol)	[l]	3,1
Engine oil capacity (10W30)	[l]	0,6
Exciter oil capacity (10W30)	[l]	0,07

HYGIENE PARAMETERS

Noise level $L_{pA,d}$	[dB]	91+4
Noise level $L_{WA,G}$	[dB]	105
Vibration a_{hvd}	[m/s ²]	8,4+3,4

FEATURES

- Frame design
- Folding handle
- Central lifting eye
- Two-staged vibration reduction
- Handling points on all sides of the machine
- Rounded edges of the plate
- Sprinkling kit (capacity of the tank 12 l)

OPTIONAL ACCESSORIES

- Soft pad for paving compaction
- Wheel kit for easy handling
- Hour counter
- Trottle lever on the handle
- Roller plate