

RANGE SERIES

LIGHTWEIGHT PLATES UP TO 200 KG

Designed to provide high handling comfort with high performance. Thanks to it these machines cover the widest range of service and maintenance work and small-scale work.

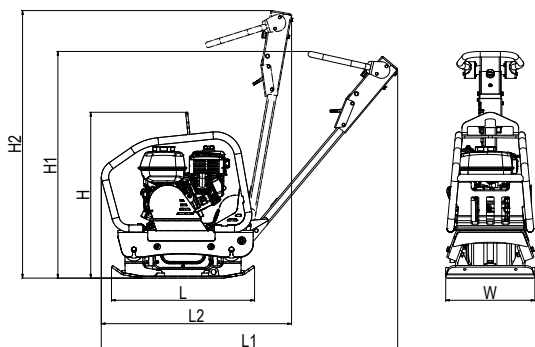



TYPE	Machine dimensions (mm)						
	H	H1	H2	L	L1	L2	W
VDR 26	680	1000	1100	700	1220	715	450

FEATURES
Frame design
Folding handle
Central lifting eye
Three-staged vibration reduction
Handling points on all sides of the machine
Rounded edges of the plate
Trottle lever on the handle

TECHNICAL PARAMETERS

OPERATIONAL PARAMETERS		
Operational weight	[kg]	160
Plate dimensions (W x L)	[mm]	450 x 700
Centrifugal force	[kN]	26
Frequency	[Hz]	95
Amplitude	[mm]	2
Area performance	[m ² /hod]	594
Climbability	[%]	30
Maximal speed	[m/min]	22

OPTIONAL ACCESSORIES	
Sprinkling kit (capacity of the tank 10 l)	<input type="checkbox"/>
Soft pad for pavement compaction	<input type="checkbox"/>
Wheel kit for easy handling	<input type="checkbox"/>
Hour counter	<input type="checkbox"/>

ENGINE		
Maker and type	Honda	GX 200
Fuel	[-]	Petrol
Net power (3600 r./min)	[kW]	4,1
Emission class	[-]	EU Stage V

OPERATIONAL FLUIDS		
Fuel tank capacity (petrol)	[l]	3,1
Engine oil capacity (10W30)	[l]	0,6
Hydraulic oil capacity (OH-HV 68)	[l]	0,2
Exciter oil capacity (10W30)	[l]	0,4

HYGIENE PARAMETERS		
Noise level L _{pA,d}	[dB]	91+4
Noise level L _{WA,G}	[dB]	105
Vibration a _{hvd}	[m/s ²]	3,2+1,6