

STANDARD SERIES

FOR THE PERFECT SURFACES

Series of walk-behind vibratory rollers for universal use for compaction of soils or asphalt. During the development of the first model in 1998 we used unique concept new to the world by which we significantly reduced the system energy losses. Since then this concept become the standard for all our future models of walk-behind rollers.

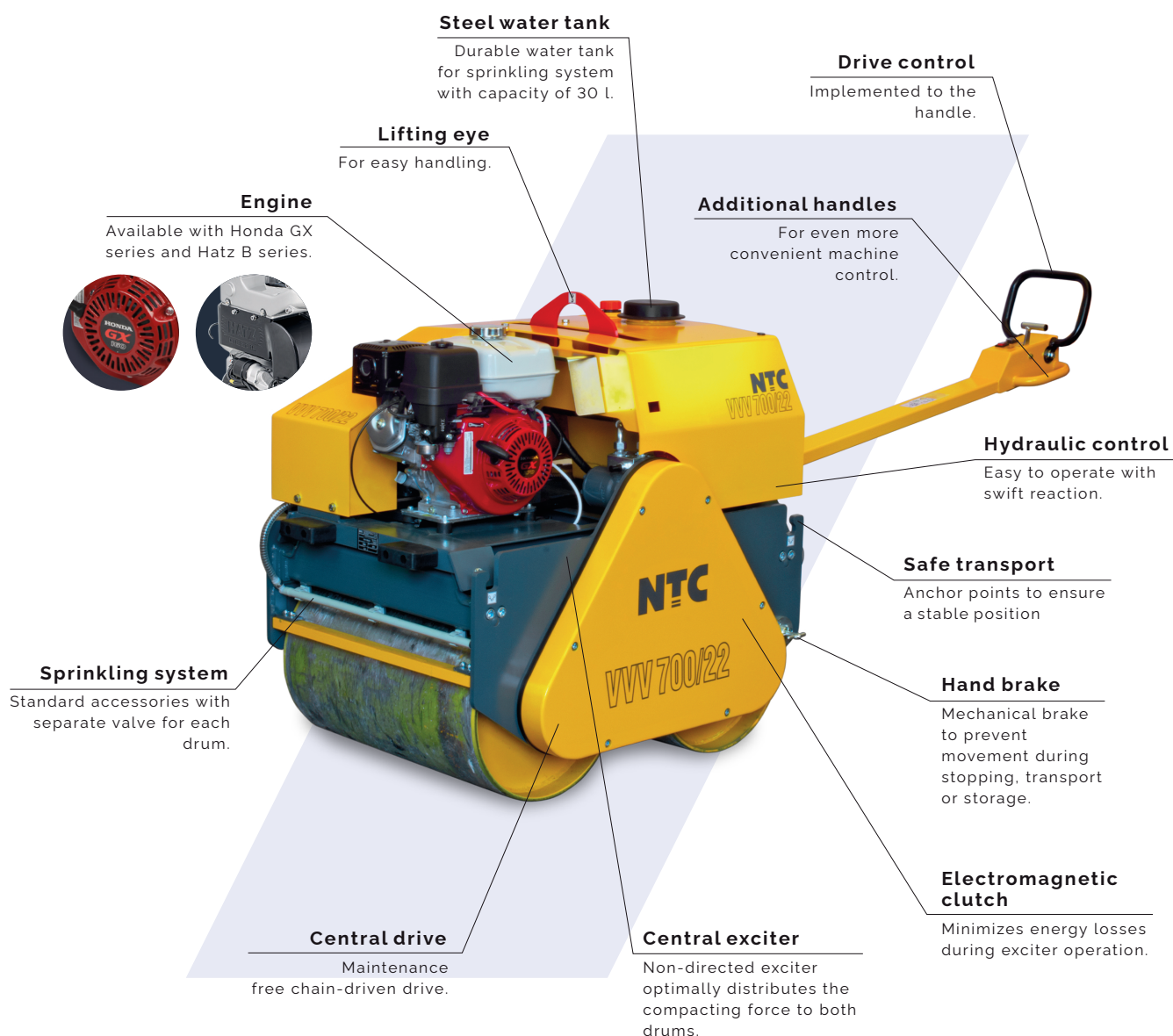

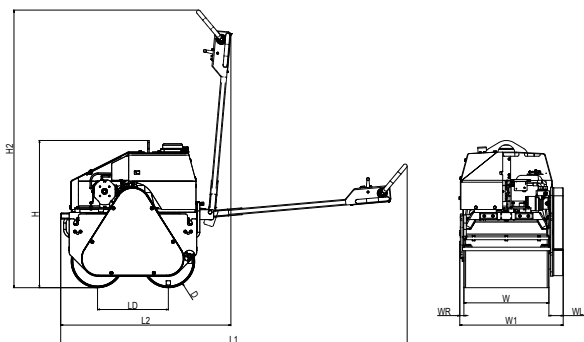

TYPE	Machine dimensions (mm)				
	H	H2	L1	L2	LD
VVV 600/12	1040	1880	2270	1085	500
	D	W	W1	WR	WL
	372	600	730	30	100

TECHNICAL PARAMETERS

OPERATIONAL PARAMETERS

Operational weight	[kg]	560
Drums width	[mm]	600
Drums diameter	[mm]	372
Centrifugal force	[kN]	12
Frequency	[Hz]	60
Amplitude	[mm]	0,6
Forward speed	[km/h]	0-5
Reverse speed	[km/h]	0-2
Area performance	[m ² /h]	3000
Climbability	[%]	40
Drum overlap left	[mm]	100
Drum overlap right	[mm]	30
Electric start	[-]	No

ENGINE

Maker and type	Honda	GX 200
Fuel	[-]	Petrol
Net power (3600 r./min)	[kW]	4,1
Cooling	[-]	Air
Emission class	[-]	EU Stage V

TECHNICAL PARAMETERS

OPERATIONAL FLUIDS

Water tank capacity	[l]	30
Fuel tank capacity (petrol)	[l]	3,1
Engine oil capacity (10W30)	[l]	0,6
Exciter oil capacity (10W30)	[l]	0,12
Hydraulic oil capacity (OH-HV 68)	[l]	9

HYGIENE PARAMETERS

Noise level L _{pA,d}	[dB]	81+4
Noise level L _{WA,G}	[dB]	105
Vibration a _{hvd}	[m/s ²]	5,14+2,06

FEATURES

Central lifting eye

Anchor points on all sides of the machine

Additional handles

Sprinkling system

Steel water tank

Hand brake

Central exciter

Electromagnetic clutch

OPTIONAL ACCESSORIES

Hour counter

