

MOVE SERIES

FOR CLEAR DEFINITION OF MOVEMENT

The electric drive of these machines with fine speed regulation increases working comfort, work efficiency and protection against machine overload or tool damage.



Control panel

All controls as cut control, throttle lever or emergency stop button are located on the main control panel for easy access.

Hand brake

As a part of drive mechanism ensures stable locked position.

Electric drive

Continuous speed control helps to meet the best cutting conditions.

Sprinkling system

Integrated with tilting water tank with capacity 33 l and sprinkling on both sides of the blade.

Side lifting eyes

To be used as a lifting eyes or as anchor points for safe transport.

Robust design

Ensures the highest durability and cut stability.

Service points

Easy access to all service points.

Engine

Available with Honda GX series.



Smooth cut

Thanks to sealed bearings used for travel wheels.

Safety pulley

Three V-belts ensures the highest level of engine protection against overload.

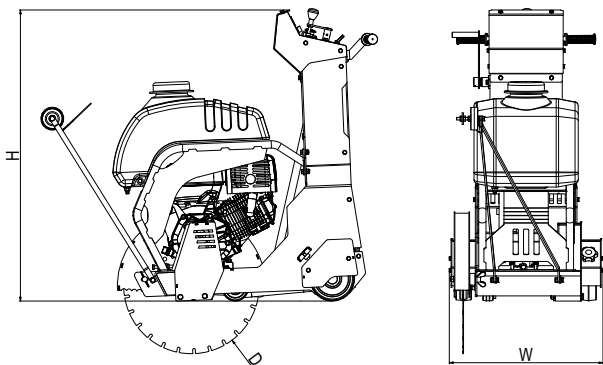

TYPE	Dimensions (mm)			
	H	W	D _{MIN}	D _{MAX}
RZ 202EP	1150	590	500	520

FEATURES
Electric drive
Frame design
Lifting and anchor eyes
Handbrake
Integrated sprinkling system
Sealed bearings in the wheels

TECHNICAL PARAMETERS

OPERATING PARAMETERS		
Weight	[kg]	185
Maximal cutting depth	[mm]	190/200
Blade diameter	[mm]	500/520
Blade connection	[mm]	25,4
Rpm w/o load	[rpm]	2500
Drive	[-]	Electric
Electric start	[-]	Yes

ENGINE		
Maker and type	Honda	GX390
Fuel	[-]	Petrol
Net power (3600 rpm)	[kW]	8,7
Cyclone filter	[-]	No
Emission class	[-]	EU Stage V

OPERATING FLUIDS		
Water tank capacity (sprinkling)	[l]	33
Fuel tank capacity (petrol)	[l]	6,1
Engine oil capacity (10W30)	[l]	1,1

HYGIENIC PARAMETERS		
Noice level L _{pA,d}	[dB]	104
Noice level L _{WA,G}	[dB]	111
Vibration a _{hvd}	[m/s ²]	14,5

OPTIONAL ACCESSORIES	
Hour counter	<input type="checkbox"/>
Diamond blade for asphalt	<input type="checkbox"/>
Diamond blade for concrete and reinforced concrete	<input type="checkbox"/>